

Cell Type CR1/3N Specifications

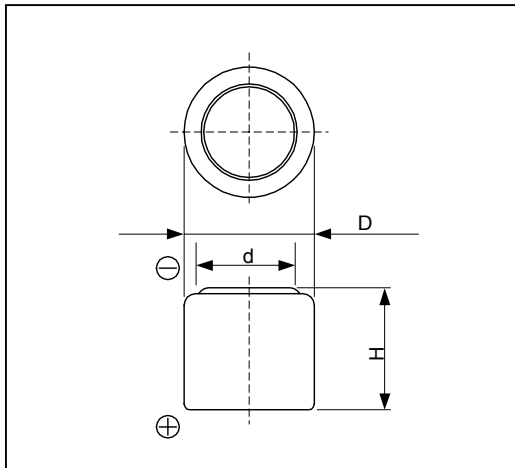

Nominal Capacity* ¹		160mAh
Nominal Voltage		3V
Standard Discharge Current		2mA
Max. Discharge Current	Continuous* ²	60mA
	Pulse* ³	80mA
Temperature Range		-40°C ~ 60°C
Weight		3.3g
Dimensions	D	11.6mm
	H	10.8mm
	d	9.1mm

*1 Nominal capacity is determined to an end voltage of 2.0V when the battery is allowed to discharge at a standard current level at 23°C.

*2 Current value is determined to be the level at which 50% of the nominal capacity is obtained with an end voltage of 2.0V at 23°C.

*3 Current value for obtaining 2.0V cell voltage when pulse is applied for 15seconds at 50% discharge depth at 23°C.

Typical Characteristics

Discharge Characteristics of CR1/3N

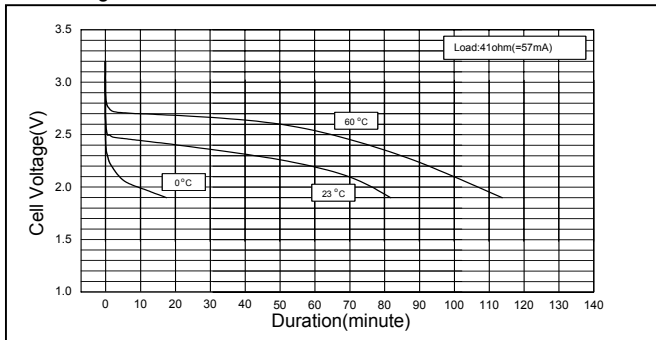

Discharge Characteristics of CR1/3N

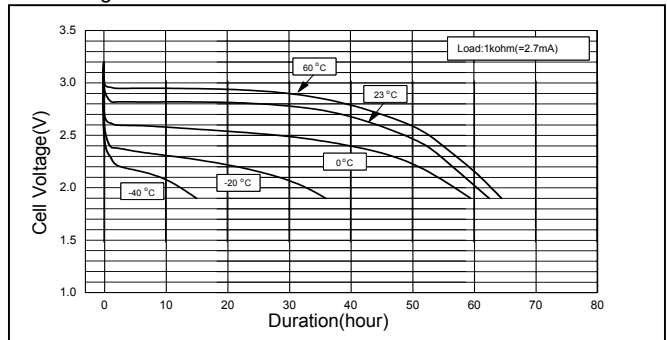

Discharge Characteristics of CR1/3N

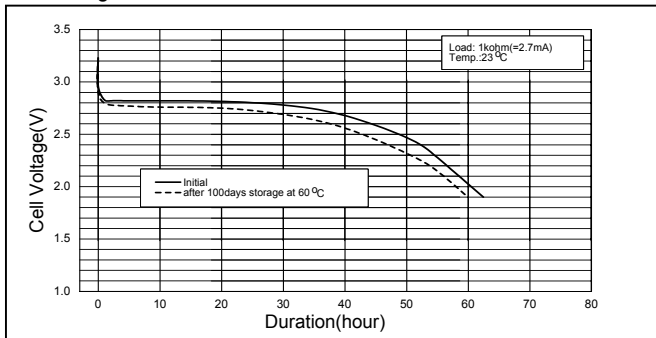

Discharge Load vs. Capacity of CR1/3N

